

*CENTRO PESQUERO ARTESANAL LO ROJAS
RECUPERACIÓN DEL BORDE COSTERO COMO ESPACIO PÚBLICO*

Comuna de Coronel, Región del Biobío

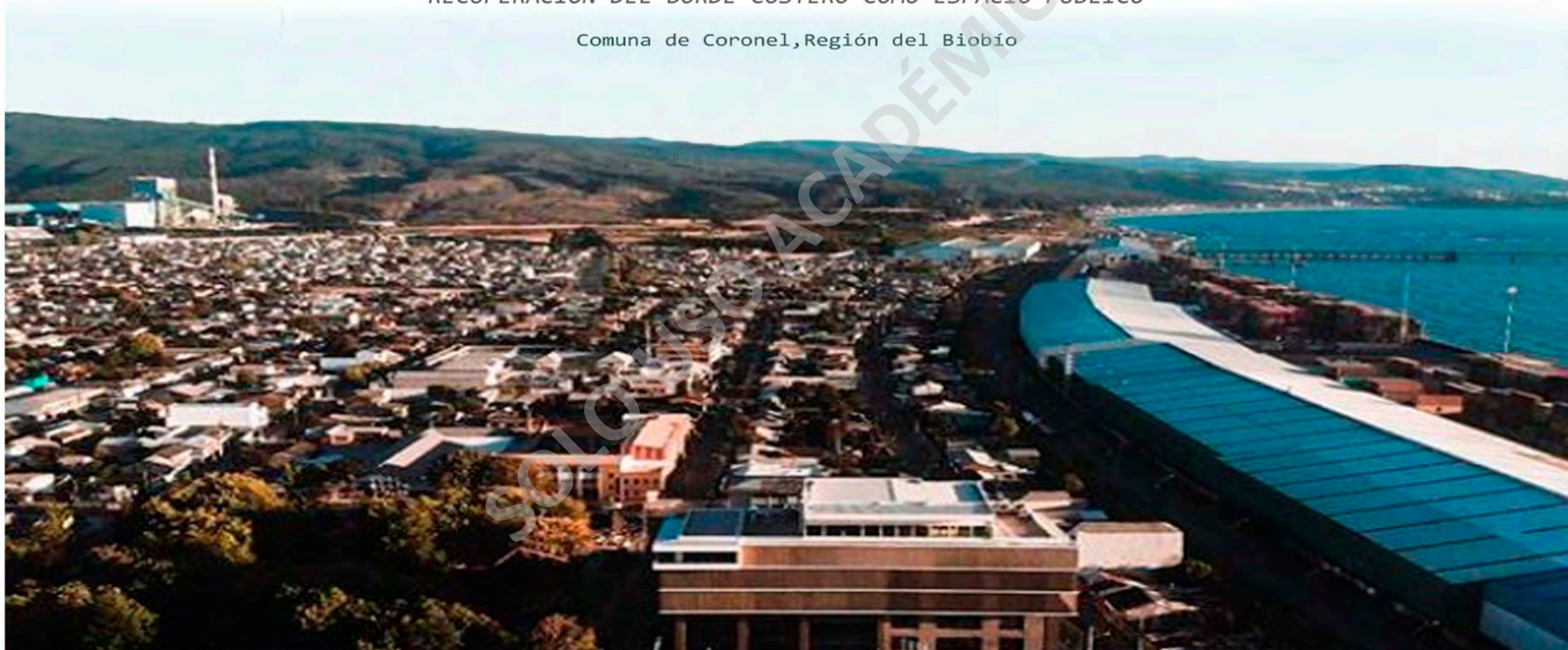



UNIVERSIDAD
MAYOR

para espíritus emprendedores

Facultad de Humanidades
**ESCUELA DE
ARQUITECTURA**

PROYECTO DE TÍTULO

Alumna

Camila Hidalgo Erices

Prof. Investigación

María Ángeles Ferrada

Prof. Taller Integrado de Titulación

Felipe Fritz

Isaías Szigeti

Prof. Proyecto de Título

Sergio Villarroel

Abril 2022

PROBLEMÁTICA

Puertos relevantes a nivel nacional

I. Sistema Portuario Norte:

- a. Puerto de Arica
- b. Puerto de Iquique
- c. Puerto de Angamos
- d. Puerto de Mejillones
- e. Puerto de Antofagasta

II. Sistema Portuario Centro

- a. Puerto de Coquimbo
- b. Puerto de Ventanas
- c. Puerto de Valparaíso
- d. Puerto de San Antonio

III. Sistema Portuario Sur

- a. Puerto de Lirquén
- b. Puerto de Penco
- c. Puerto de Talcahuano-San Vicente
- d. Muelles Puchoco y Jureles
- e. Puerto de Coronel

IV. Sistema Portuario Austral

- a. Puerto Corral
- b. Puerto Montt
- c. Puerto Chacabuco
- d. Empresa Portuaria Austral



Ciudad puerto de Valparaíso, Región de Valparaíso



Ciudad puerto de San Antonio, Región de Valparaíso



Puerto de San Vicente, Talcahuano, Región del Bío Bío



Ciudad puerto de Coronel, Región del Bío Bío

Ciudad de Coronel 1910



Ciudad de Coronel 2019



Limite generado por el puerto



UBICACIÓN

Región del Bio-Bio _Área urbana de Coronel

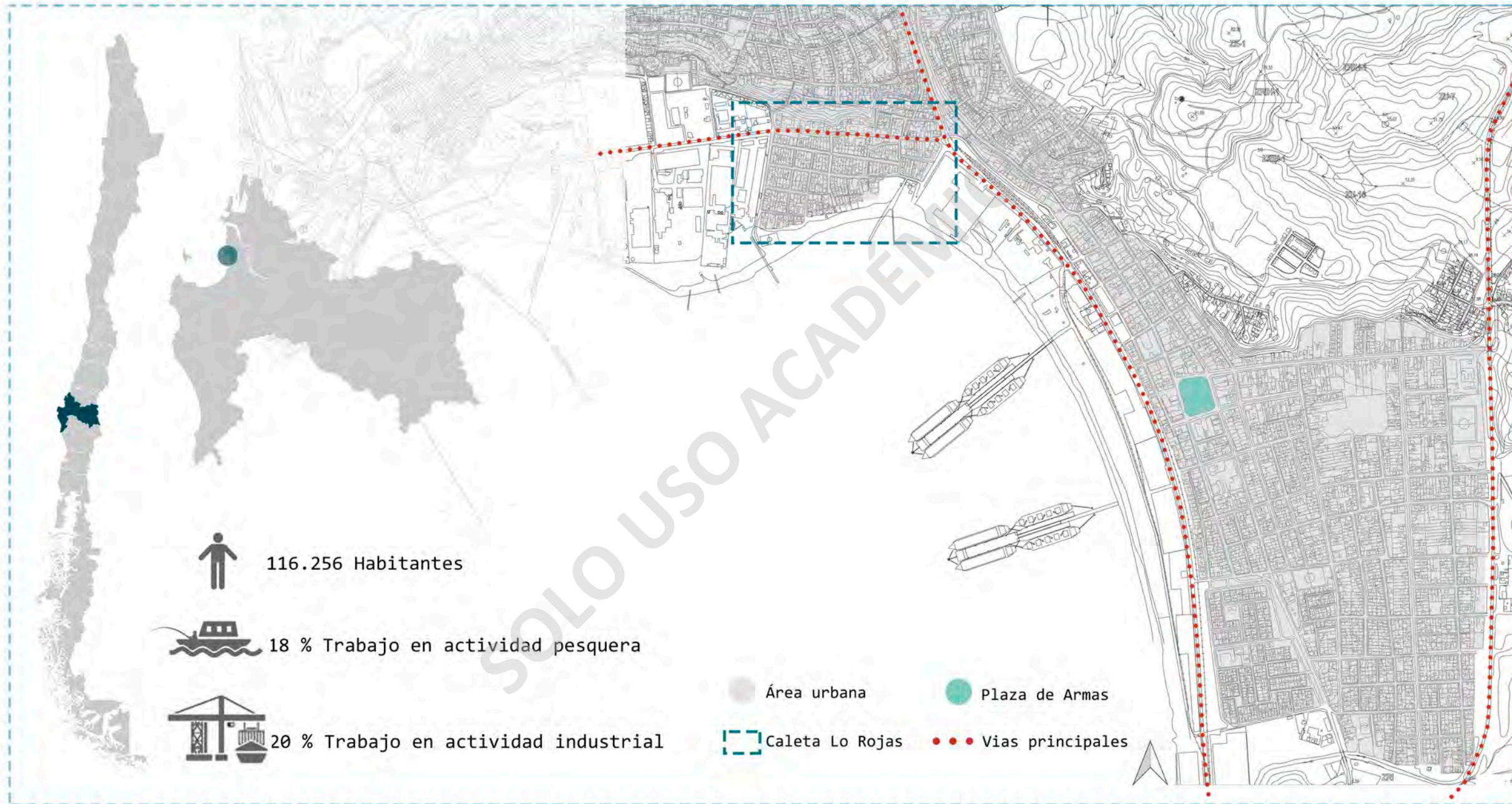

UBICACIÓN

Área urbana de Coronel

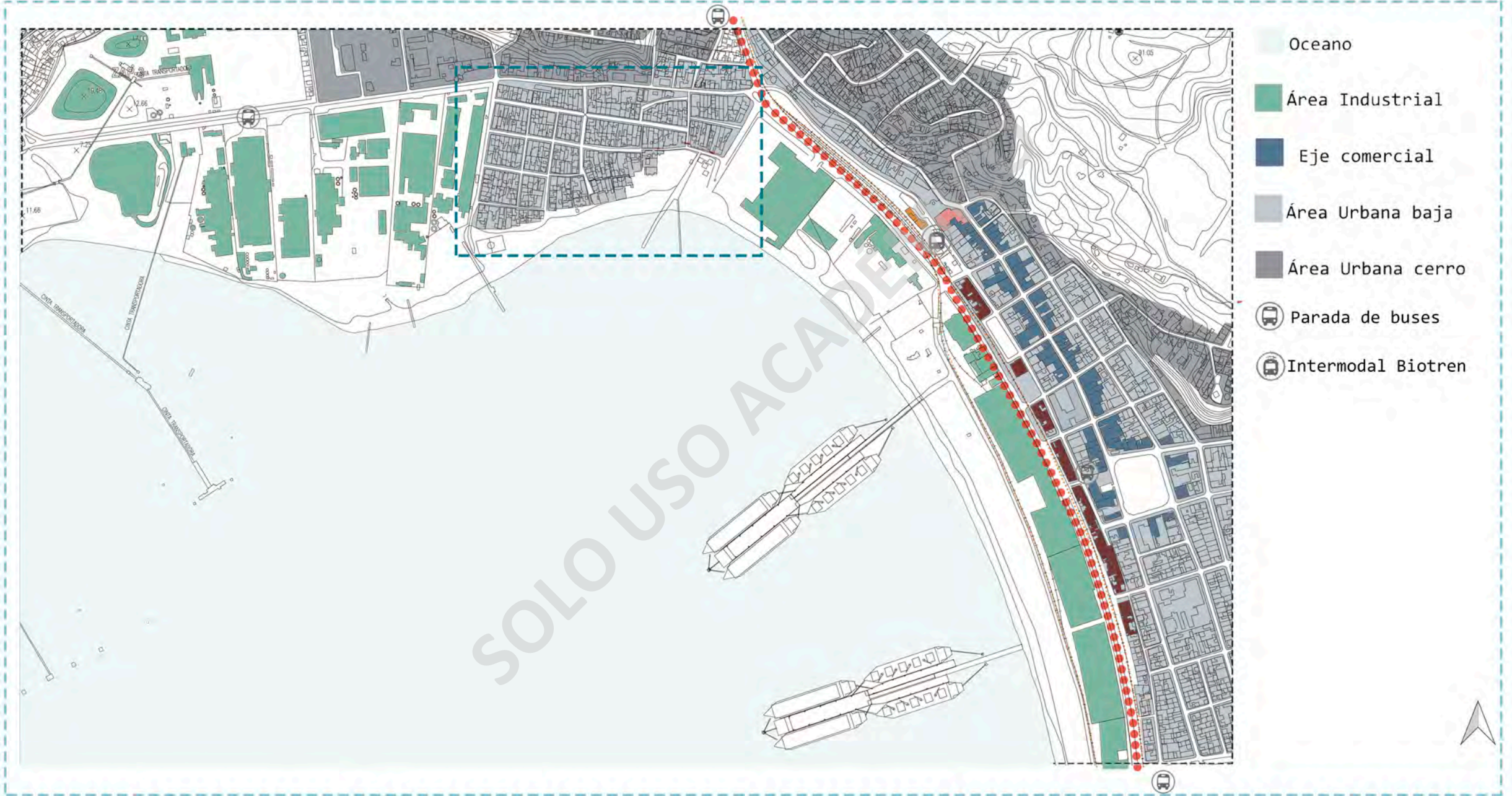

UBICACIÓN

Área urbana de Coronel_Borde costero recorrible



UBICACIÓN

Área urbana de Coronel_Borde costero recorrible

1



2



3



4



5



6



UBICACIÓN

Área urbana de Coronel_Borde costero recorrible

7



8



8



9



10



11



LUGAR

Área de trabajo _Población / Caleta Lo Rojas

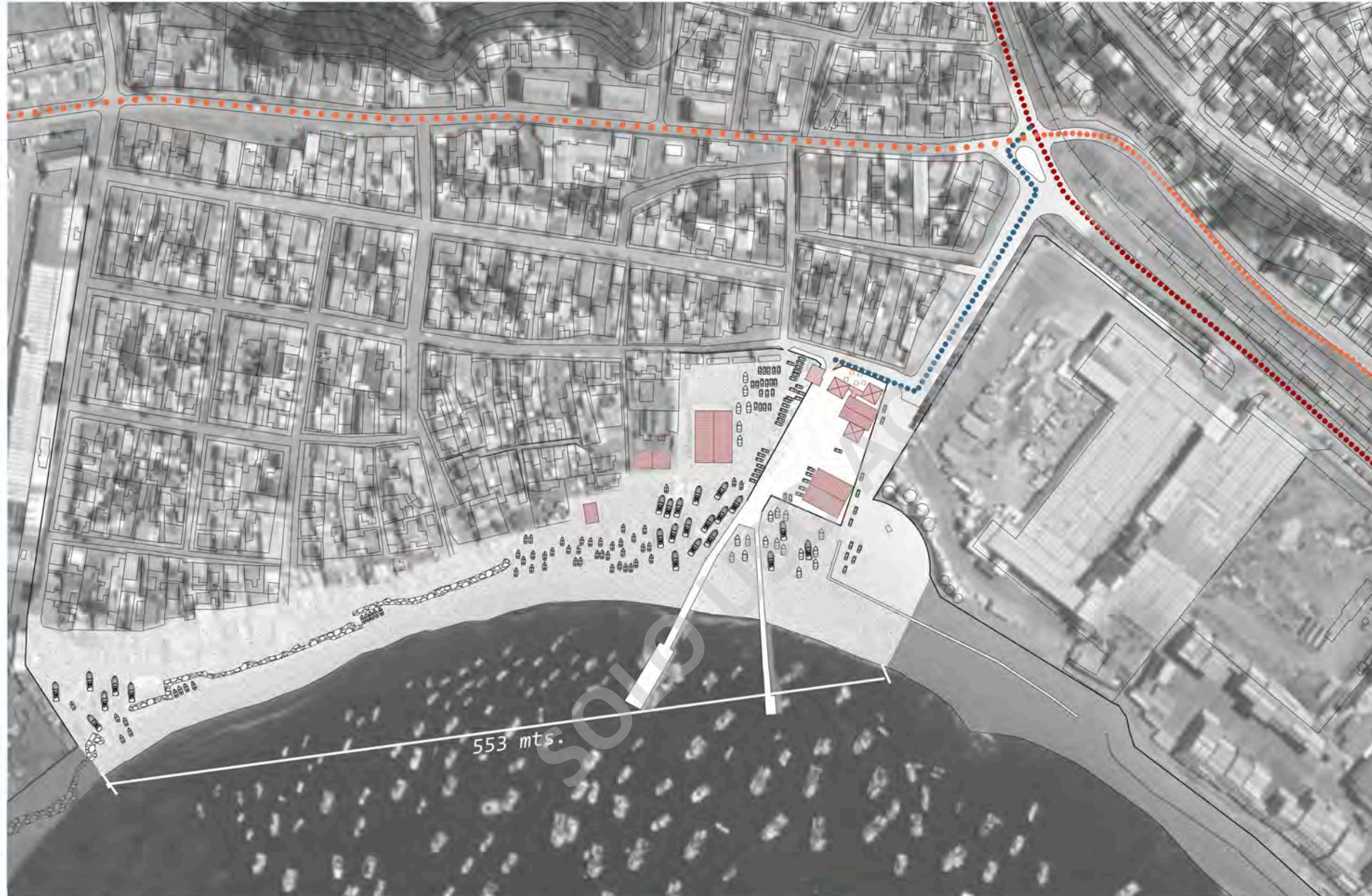

- ● ● Via de acceso al centro de coronel / Norte-Sur
- ● ● Via de acceso al centro de coronel / oriente-poniente
- ● ● Acceso Caleta Lo Rojas
- Infraestructura Caleta

553 MTS APROX.

Extencion lineal a trabajar



LUGAR

Área de trabajo _Población / Caleta Lo Rojas

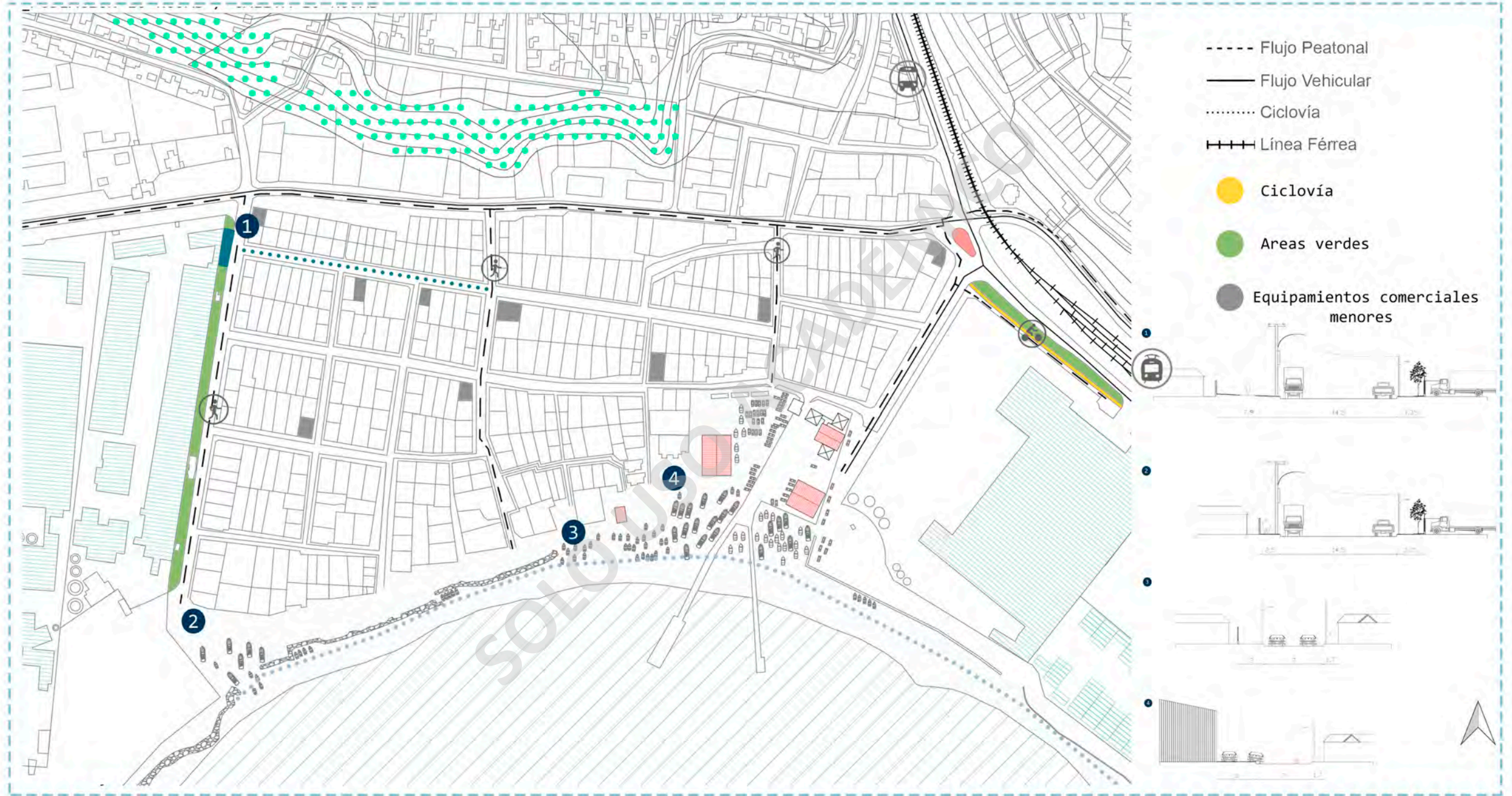

1



Actividades
junta de vecinos

2



Zona reparación
embarcaciones

3

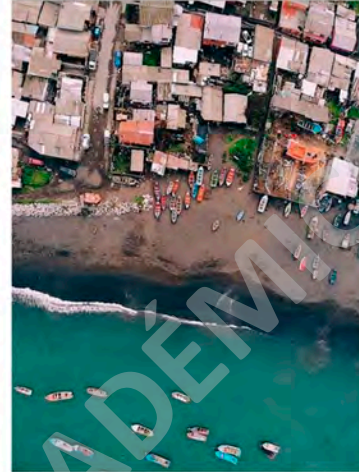

Zona
reparacion de redes

4



Secado de pescado



Desfiles
y
celebraciones



Peregrinación San Pedro
29 Junio



Fiesta Costumbrista
del Pescado Ahumado
mediados de noviembre



Venta de pescados y mariscos
lunes a sabado - 10:00 a 16:00

LUGAR
Relación Viviendas y borde costero_Población / Caleta Lo Rojas

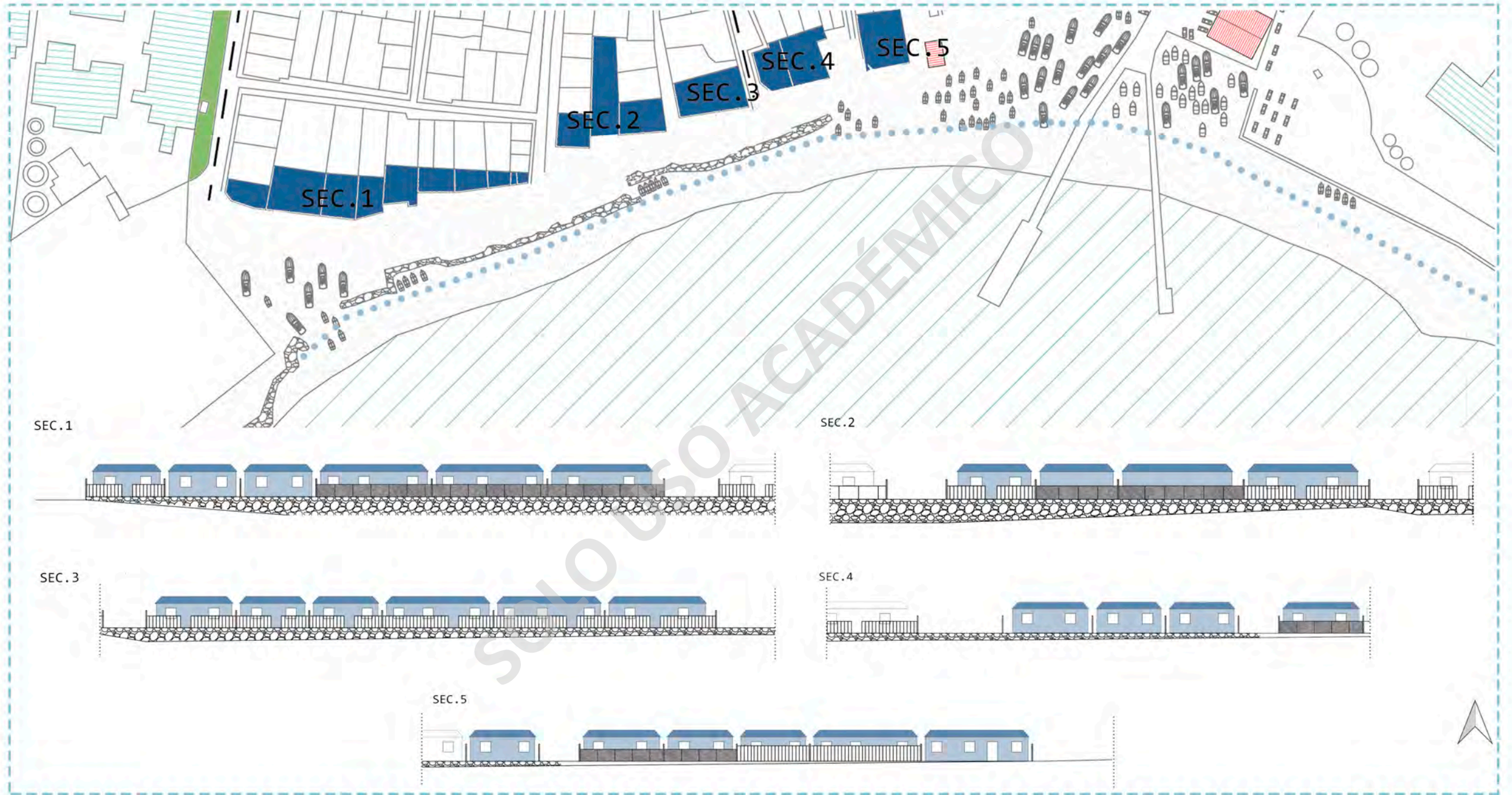

5

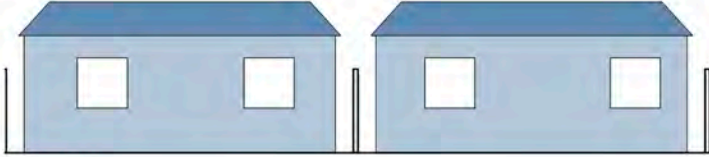

10

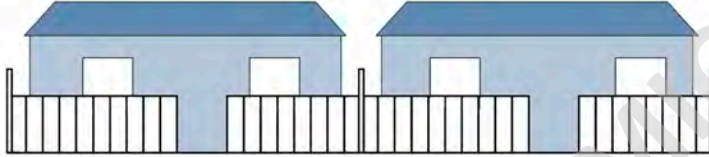

9

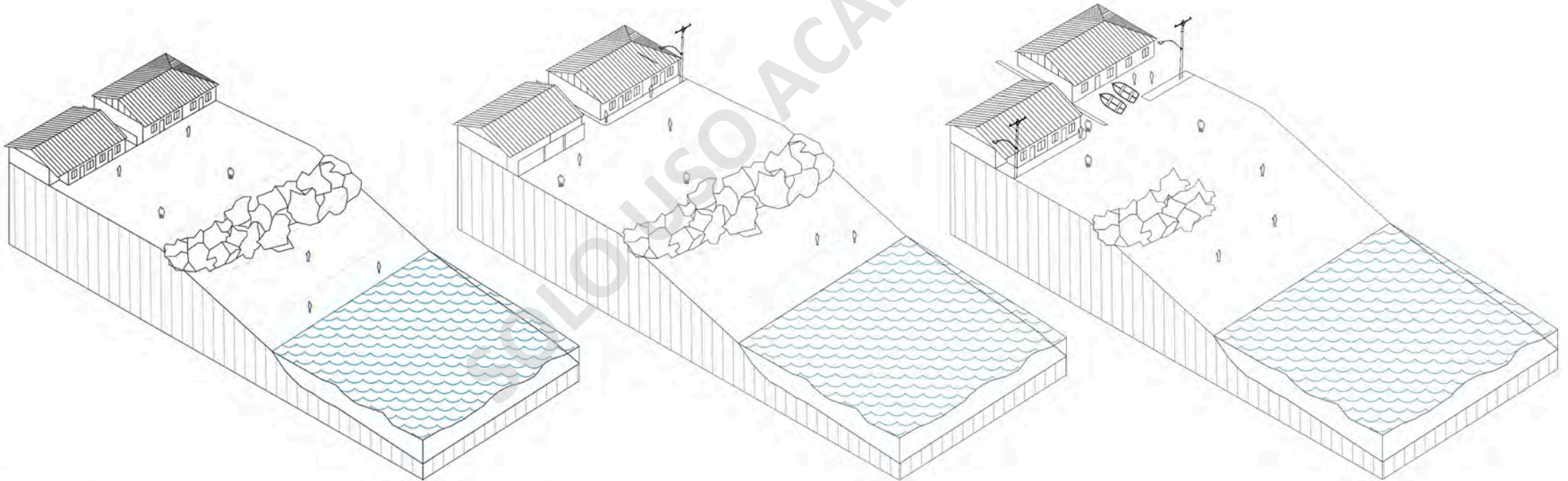
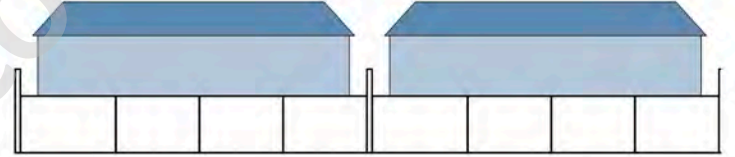

LUGAR
Relación Viviendas y borde costero_Población / Caleta Lo Rojas

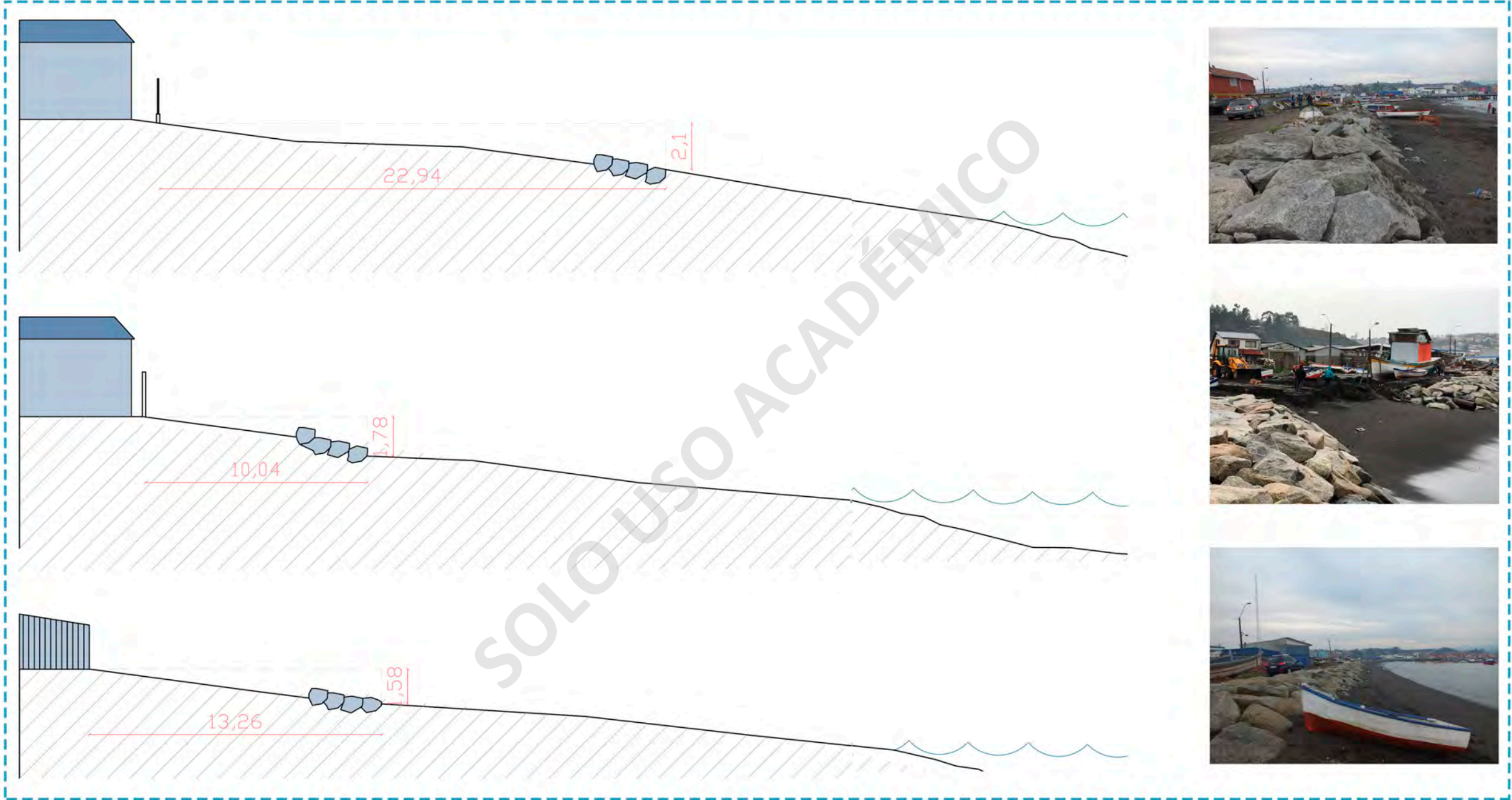



3.649
pescadores inscritos



283
Embarcaciones Inscritas



1
sindicatos de charqueadoras

4
sindicatos de pescadores oficiales

1

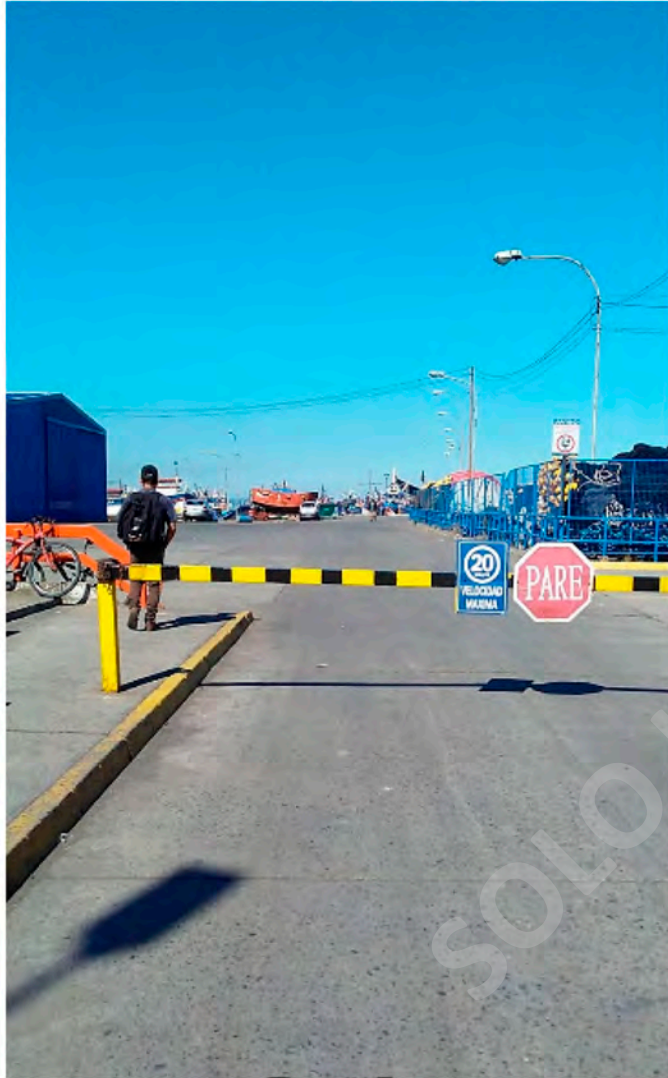

2



3



4



CASO PROGRAMATICO
Equipamiento caleta Lo Rojas



- 1 Oficinas de sindicatos y alcaldía de mar
250 M2
- 2 Zona de bodega
400 M2
- 3 Multicancha
600 M2
- 4 Zonas de venta (2 locales comerciales)
60 M2
- 5 Muelles nuevo y antiguo



CASO PROGRAMATICO
Equipamiento caleta Lo Rojas

1

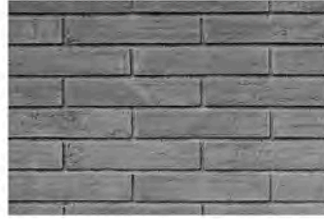
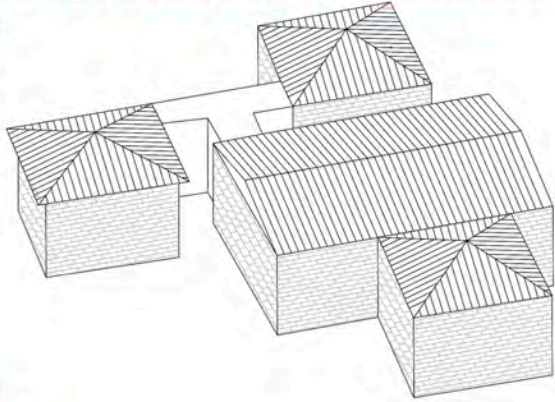

2

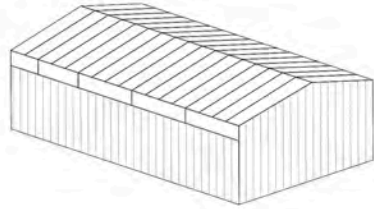

3

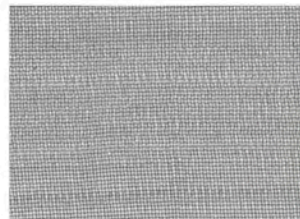
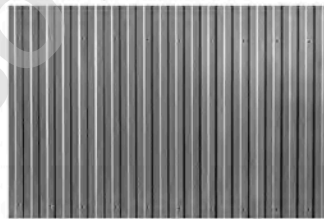
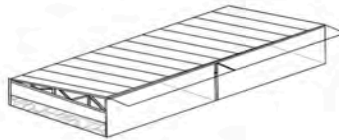

4

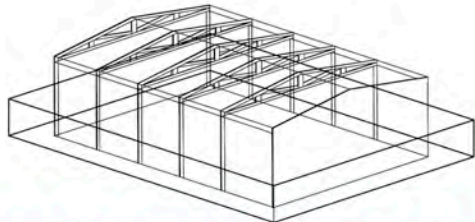

5

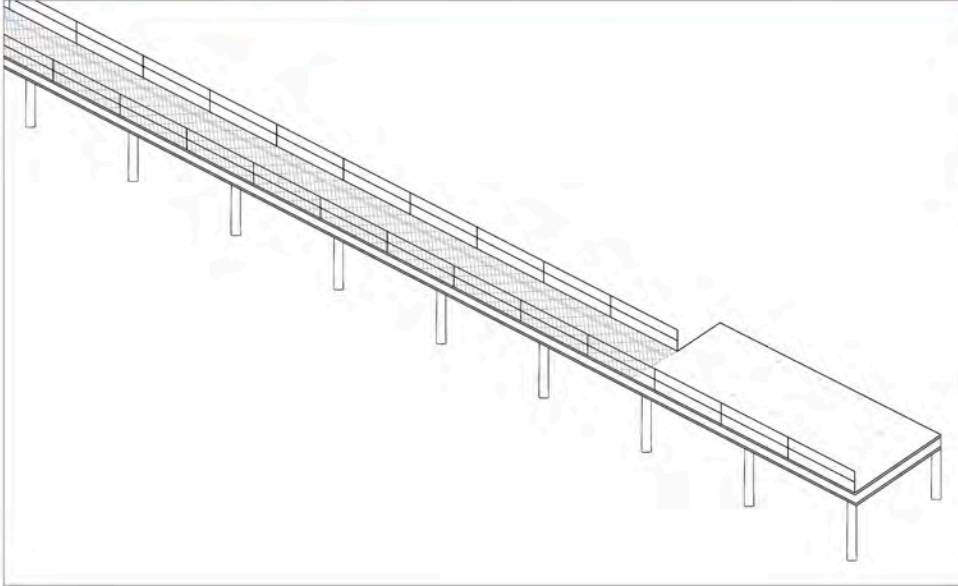

Muelle antiguo de la caleta

LARGO: 100 MTS.

ÁREA DE CARGA : 10 X 5 MTS.

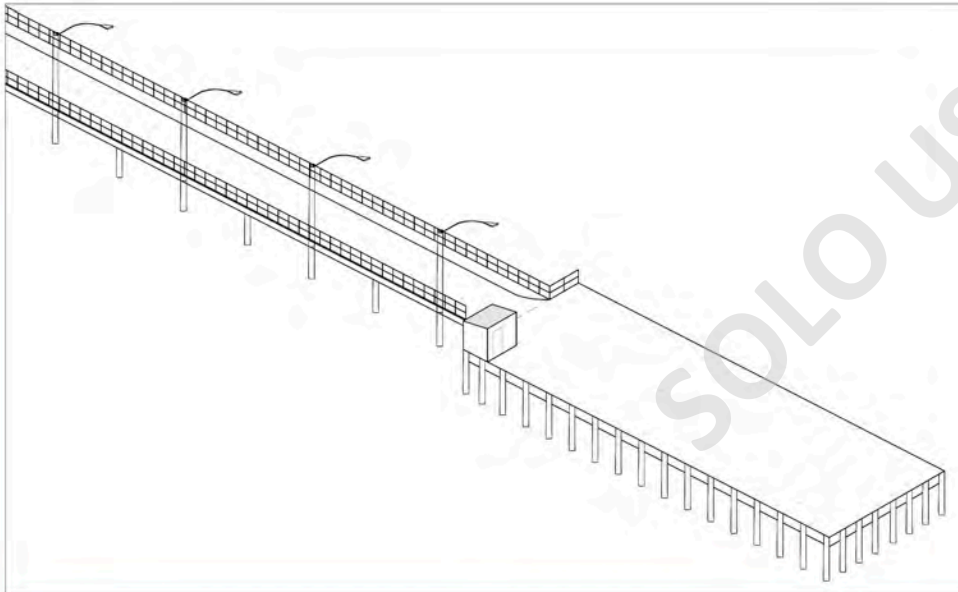

Muelle nuevo de la caleta año 2017

LARGO : 130 MTS.

ÁREA DE CARGA : 10 X 30 MTS.

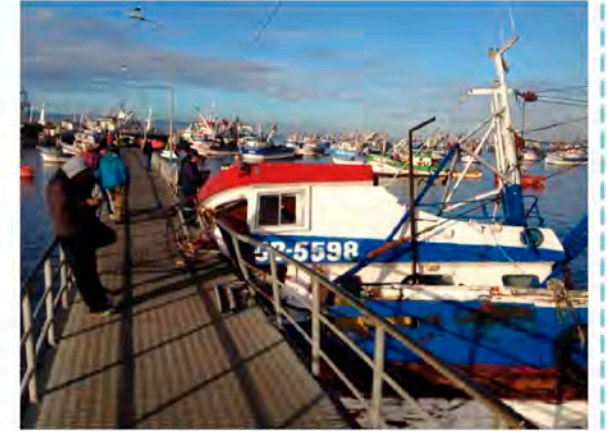

Normativa del borde /3 zonas distintas de normativa



- ZAC 1 - Zona de asentamiento costero
- ZTBC 1 - Zona turística de borde pesquero
- ZP 1 - Zona protección borde costero

¿QUÉ ACTIVIDADES SE PUEDEN DESARROLLAR EN LAS CALETAS?

“...Se podrán realizar todas aquellas labores vinculadas con el desarrollo de las actividades pesqueras extractivas y de transformación, de pesca recreativa... También se pueden llevar a cabo otras actividades productivas, comerciales, culturales o de apoyo, relacionadas directamente o indirectamente con la pesca, tales como turismo, puestos de venta de productos de mar y artesanía local, gastronomía y estacionamientos ...”

art.4 de la ley de caletas, Septiembre 2017





A partir del mesas participativas con los sindicatos y dirigentes se llegó a definir un programa para impulsar emprendimientos y el sector pesquero.

- Pensiones.
- Restaurantes.
- Secado de algas.
- Centro de eventos.
- Sede Social.
- Acuicultura.
- Centro recreacional.
- Cancha techada.
- Flota de taxis y colectivos.
- Servicios de comercialización
- Bodejate de productos.
- Cocineria
- Sede deportiva.





A partir de las mesas participativas con los sindicatos y dirigentes se llegó a definir un programa para impulsar emprendimientos y el sector pesquero.

- Pensiones.
- Restaurantes.
- Secado de algas.
- Centro de eventos.●
- Sede Social.●
- Acuicultura.
- Centro recreacional.
- Cancha techada.
- Flota de taxis y colectivos.
- Servicios de comercialización
- Bodegaje de productos.
- Cocinería
- Sede deportiva.





El municipio a planteado un conjunto de estrategias orientadas a introducir la naturaleza en los espacios públicos de la ciudad, cambiando positivamente las condiciones del entorno urbano y mejorando así los estándares de vida, salud y confort de las personas que viven en Coronel.

Desde la puesta en marcha del plan verde en el año 2010, Coronel incremento sus áreas verdes públicas pasando de 17 hectáreas a más de 60 hectáreas en menos de 10 años.

Se genera un catalogo de implementación base en conjunto con el observatorio ecologico de coronel:

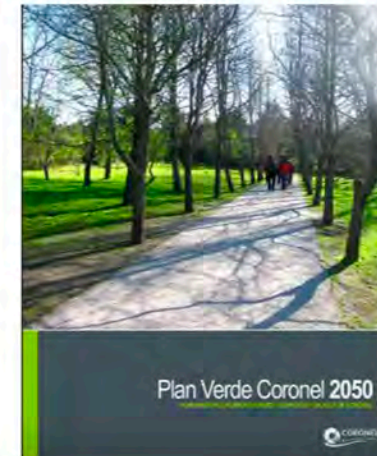

CASO PROGRAMATICO

"Plan Verde Coronel 2050" _ Propuesta Plan Maestro áreas verdes y espacios publicos de Coronel

ESPECIES ARBUSTIVAS:

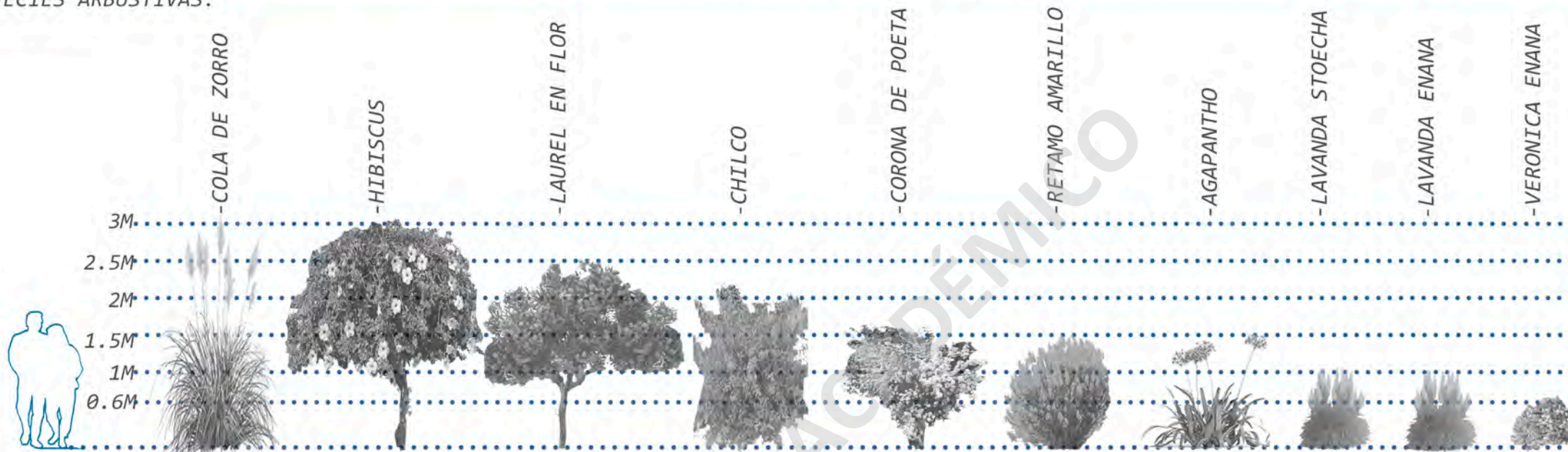

ESPECIES CUBRE SUELOS:

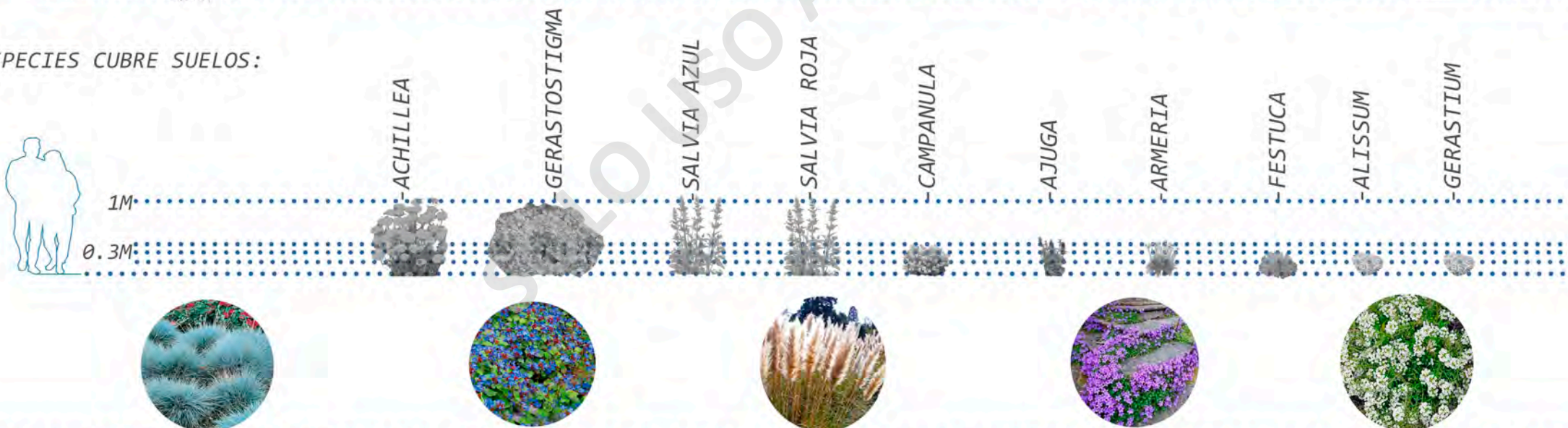

CASO PROGRAMATICO

Equipamiento mínimo para el funcionamiento de una caleta



ZONA DE PESCADORES.

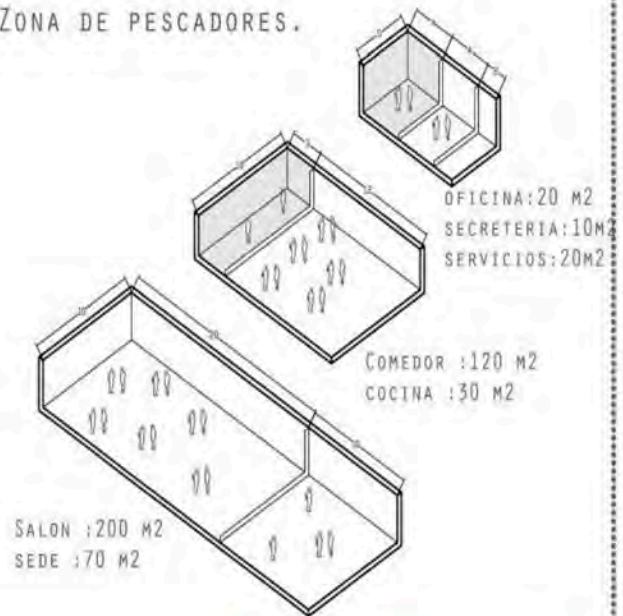

ZONA CARPINTERIA.

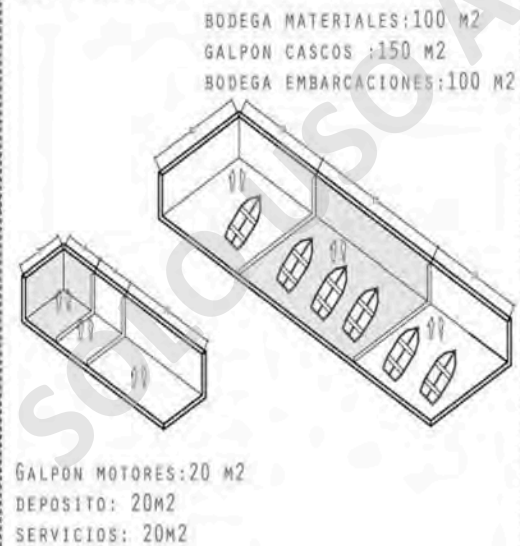

ZONA DE MANTENCIÓN.



ZONA PUBLICA.

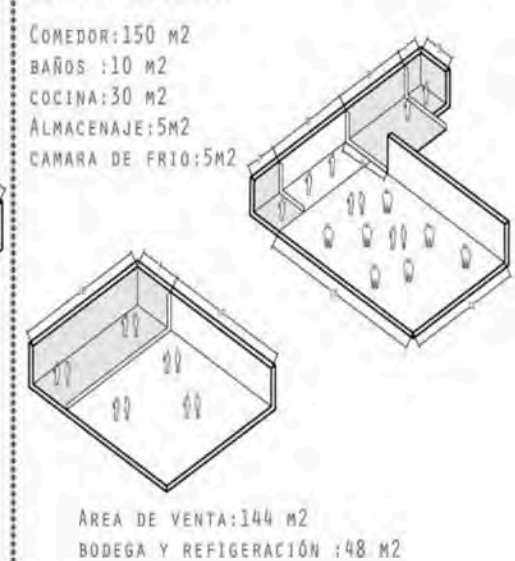

Fuente:Elaboración propia en base al estudio de caletetas.







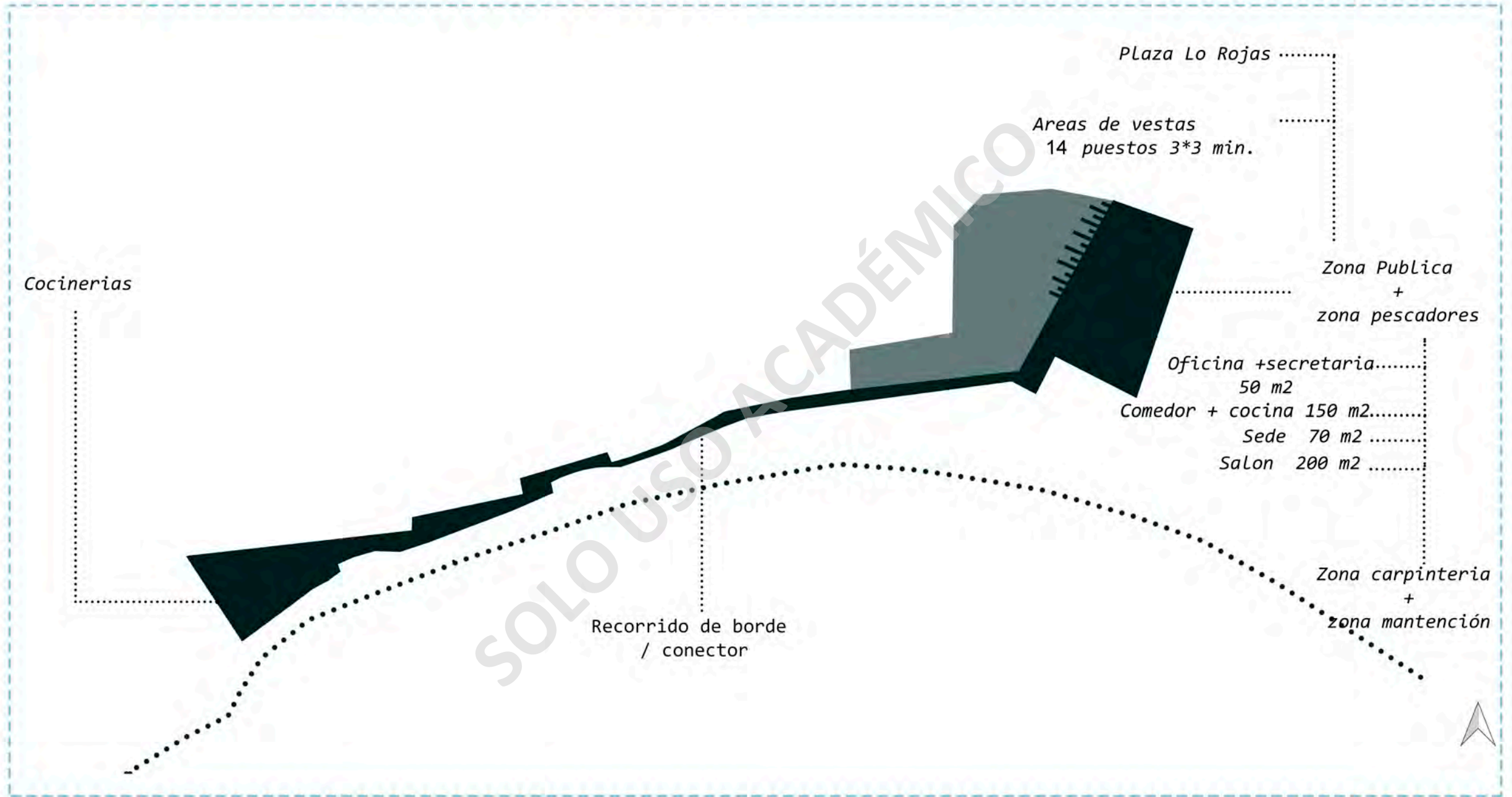

Los factores naturales mas frecuentes que nos encontra en zonas costeras son:

- Subidas de Marea
- Lluvias
- Vientos
- Salinidad
- Humedad relativa

Temperatura promedio anual:

invierno : 8,5 °

verano : 24 °

Luvias :

1256,2 mm anuales
siendo los meses de mayo y junio los que tiene un nivel mas alto de precipitaciones

Humedad Relativa:

66 % en un nivel promedio



Solsticio de Invierno
21 junio 37°

Solsticio de verano
21 diciembre 76°





Eliminación infraestructuras existentes

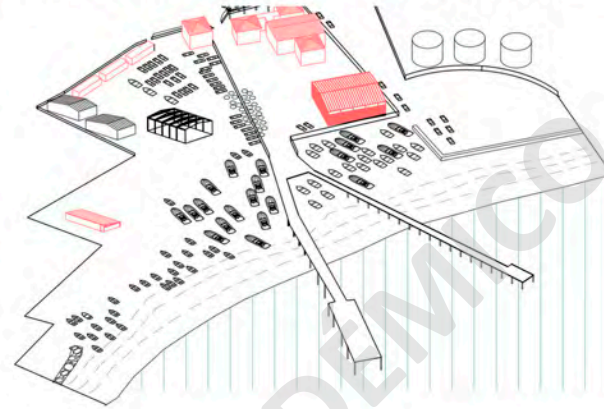



Eliminación infraestructuras existentes

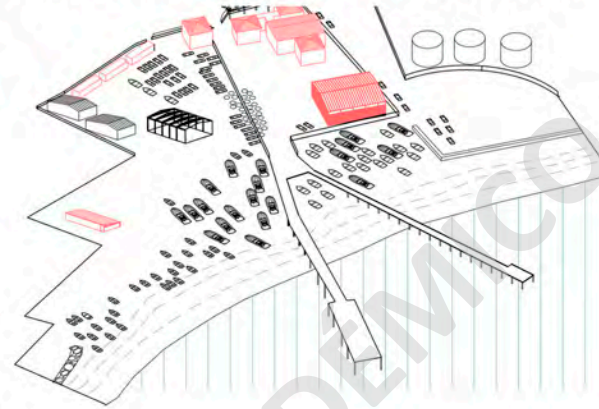

Eliminación cierres perimetrales





Eliminación infraestructuras existentes

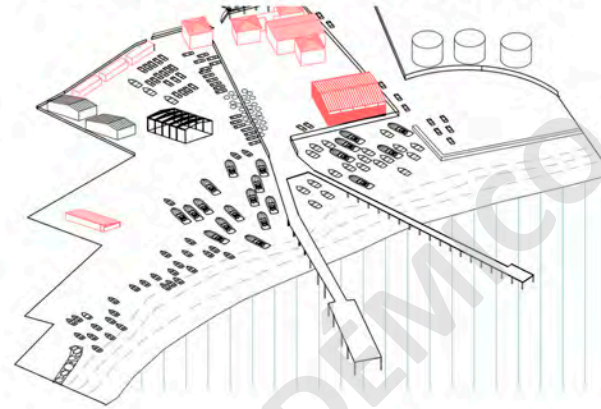

Eliminación cierres perimetrales



Formación de un limite

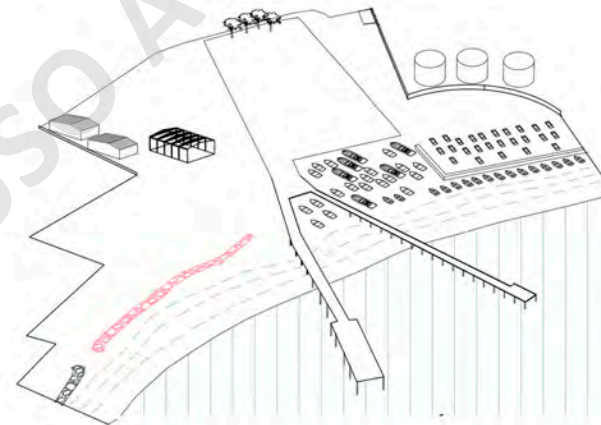



Eliminación infraestructuras existentes

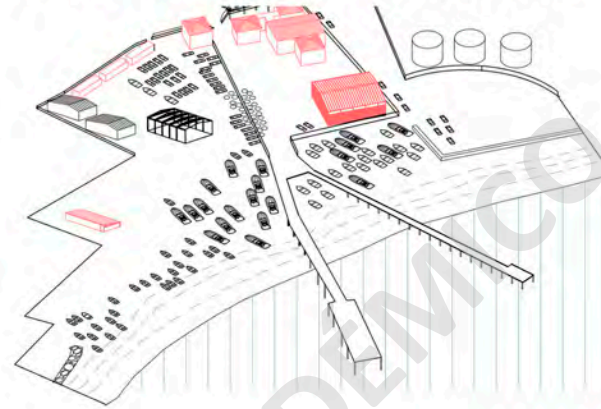

Eliminación cierres perimetrales



Formación de un limite

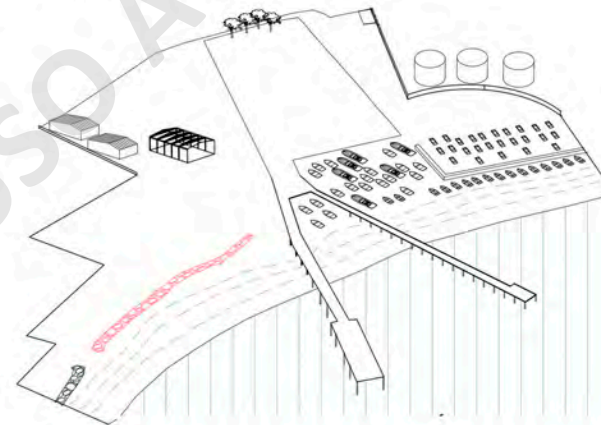

Agrupación de los programas

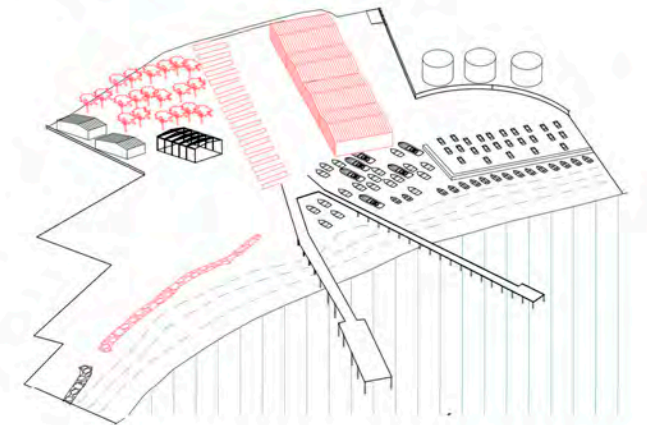

PARQUE URBANO KAUKARI / COPIAPO_TEODORO FERNANDEZ

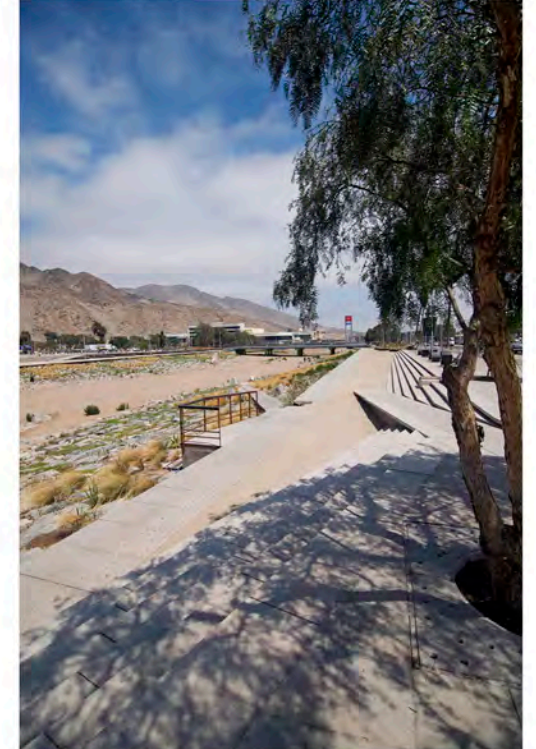

Mercado del puerto / vodice - Croacia
2015



Caleta Coloso_Segundo lugar / Parque B.C Antofagasta
2017



Versatilidad cubierta a dos aguas Galpones y Muticancha

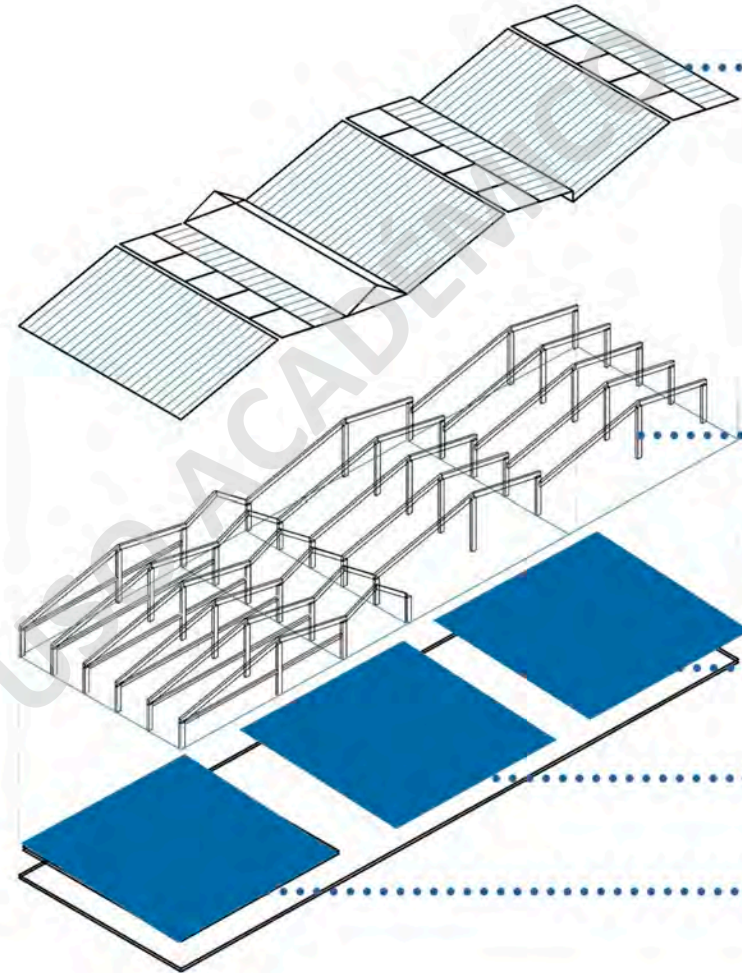
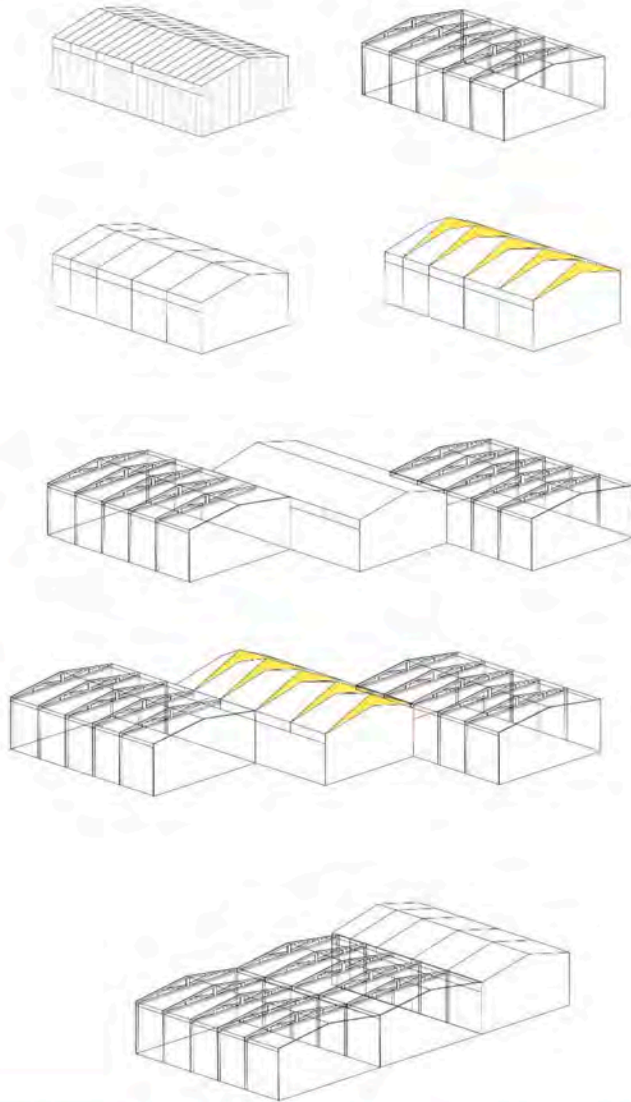

Cubierta unificadora de programas

estructura permeable y resistente al clima o fenomenos naturales

Programa de venta y produccion

Programa administrativos y de pescadores

Programa de mantención y reparaci3n

ESTRATEGIA PROYECTUAL

Flujos principales para generar estrategia de recorrido



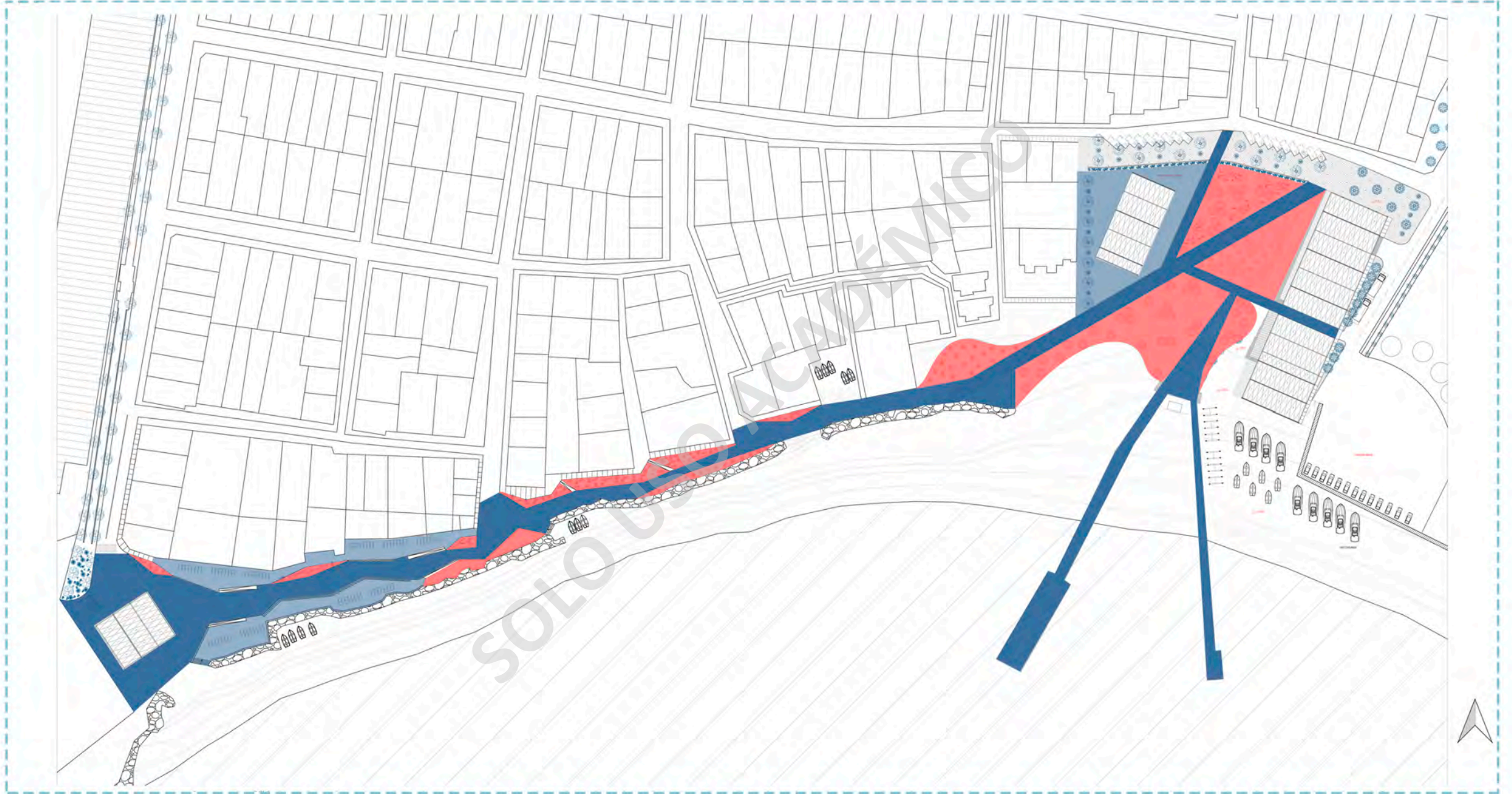



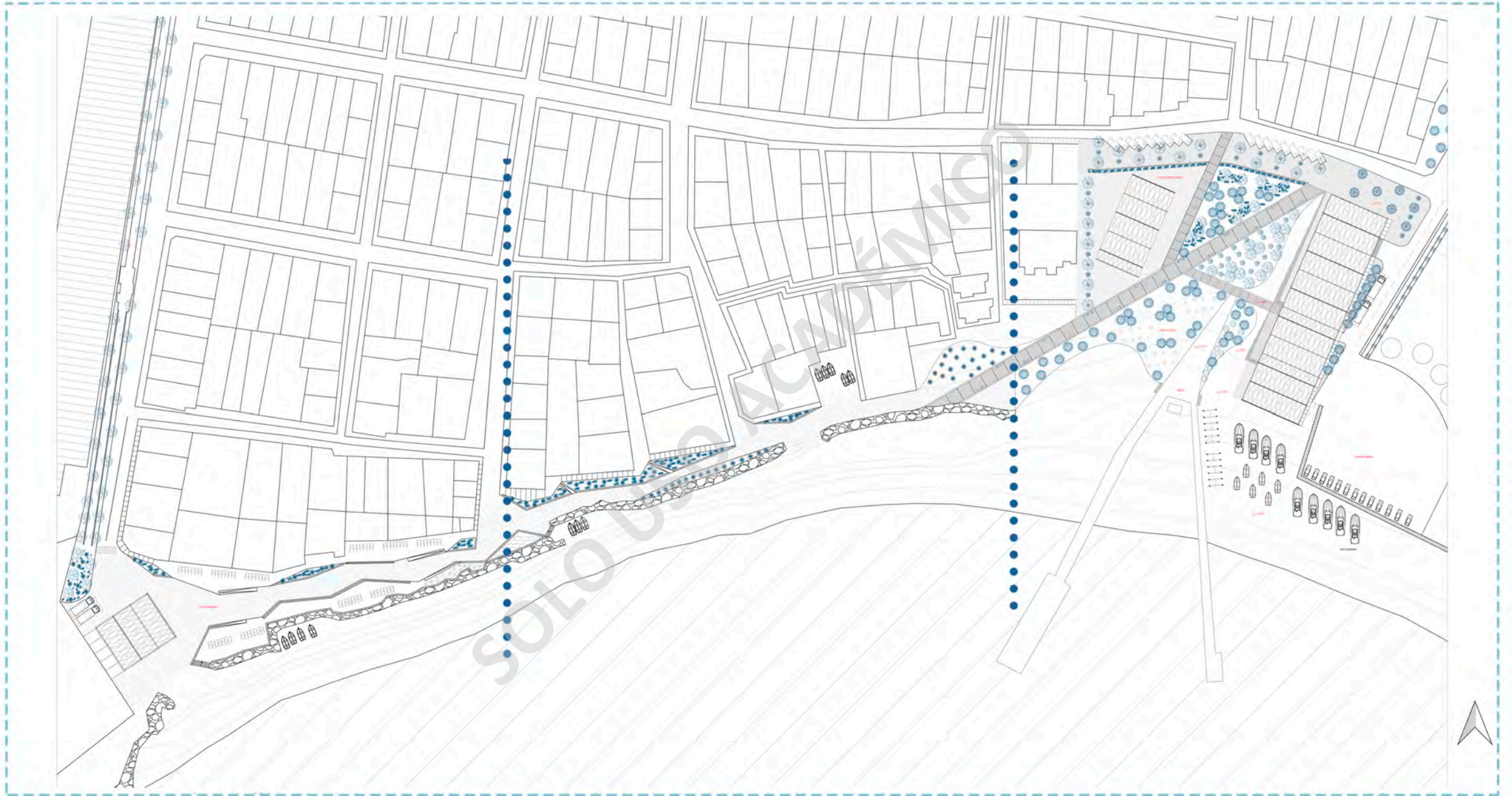



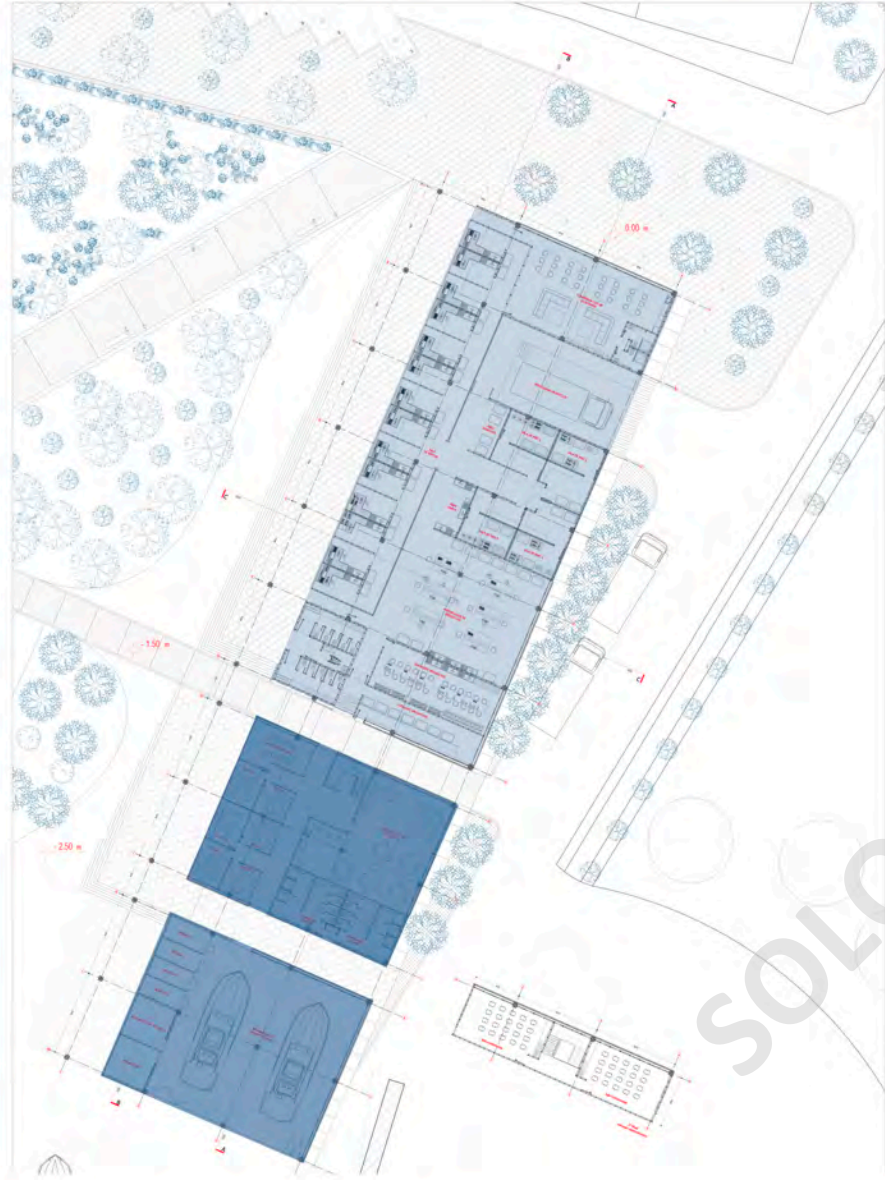

SOLO USO ACADÉMICO



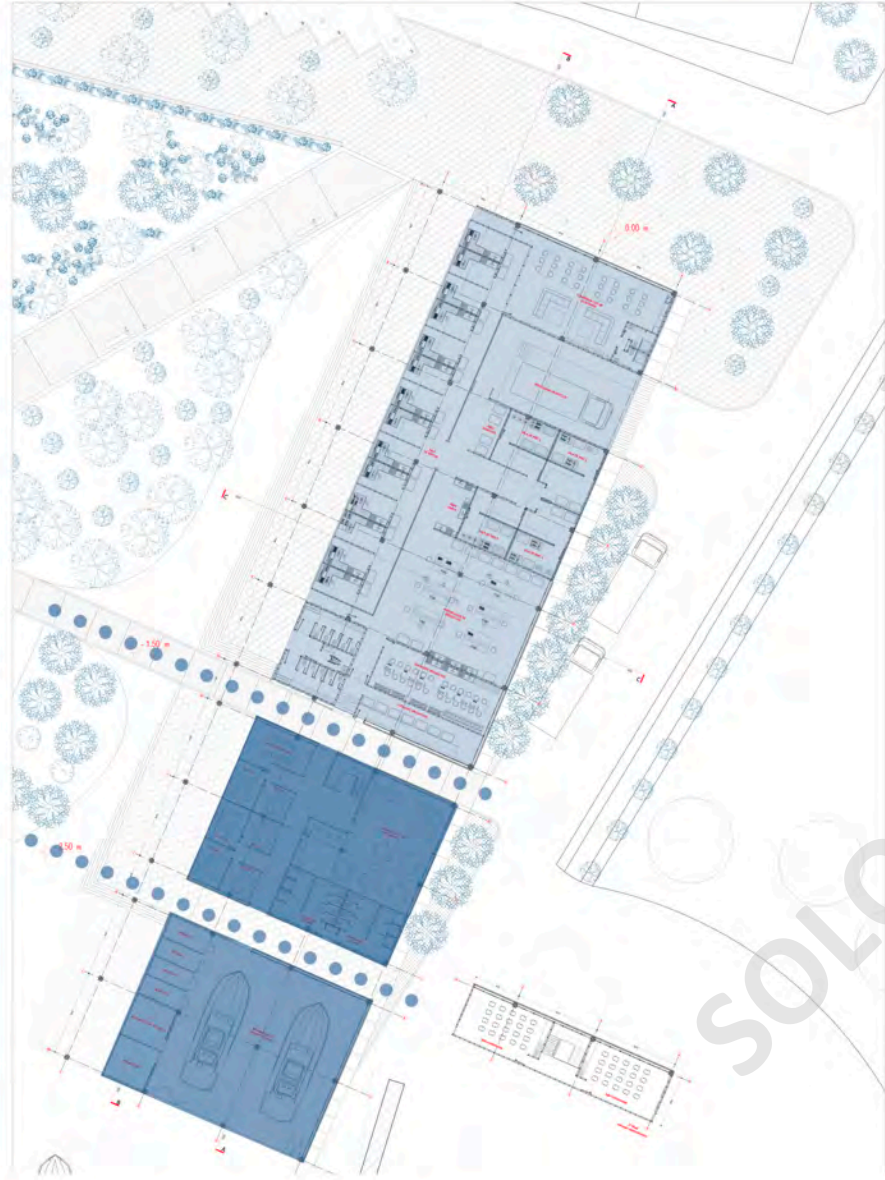

SOLO USO ACADÉMICO



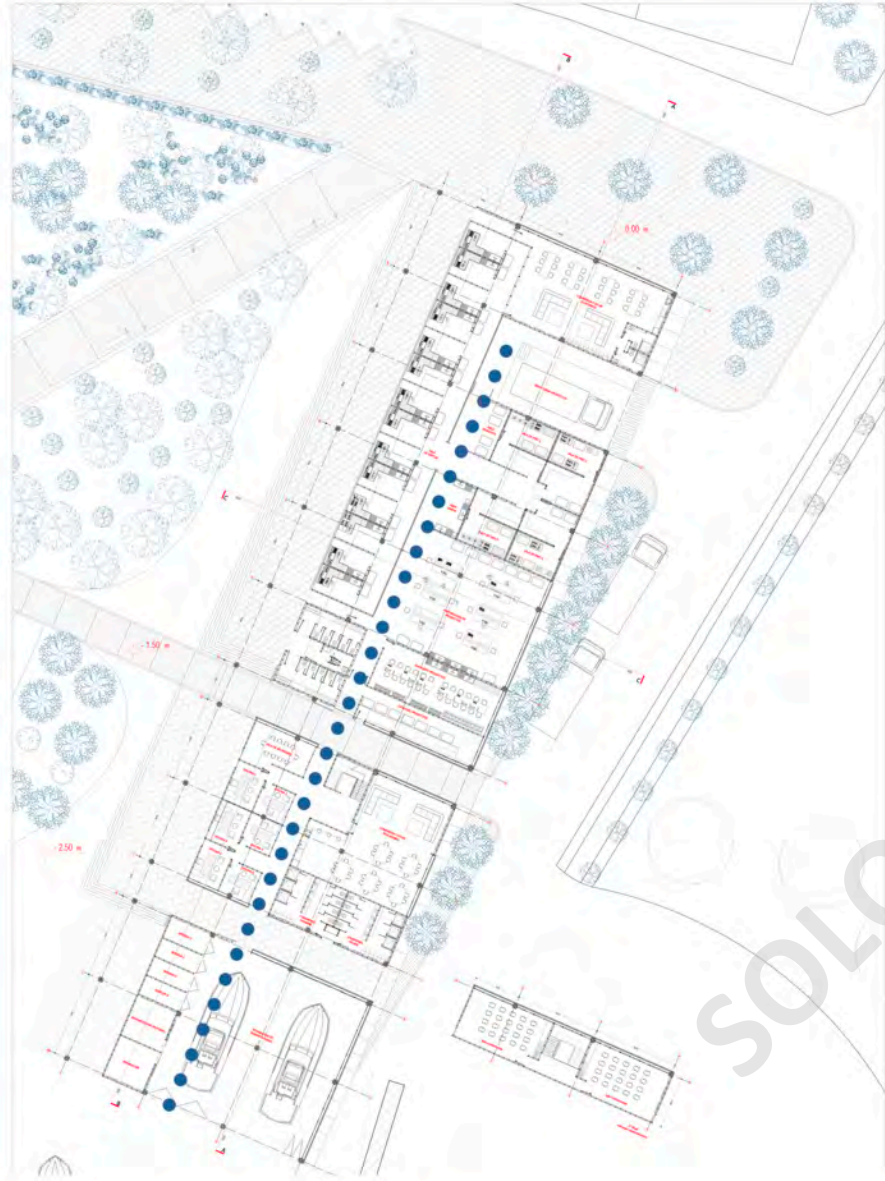

SOLO USO ACADÉMICO



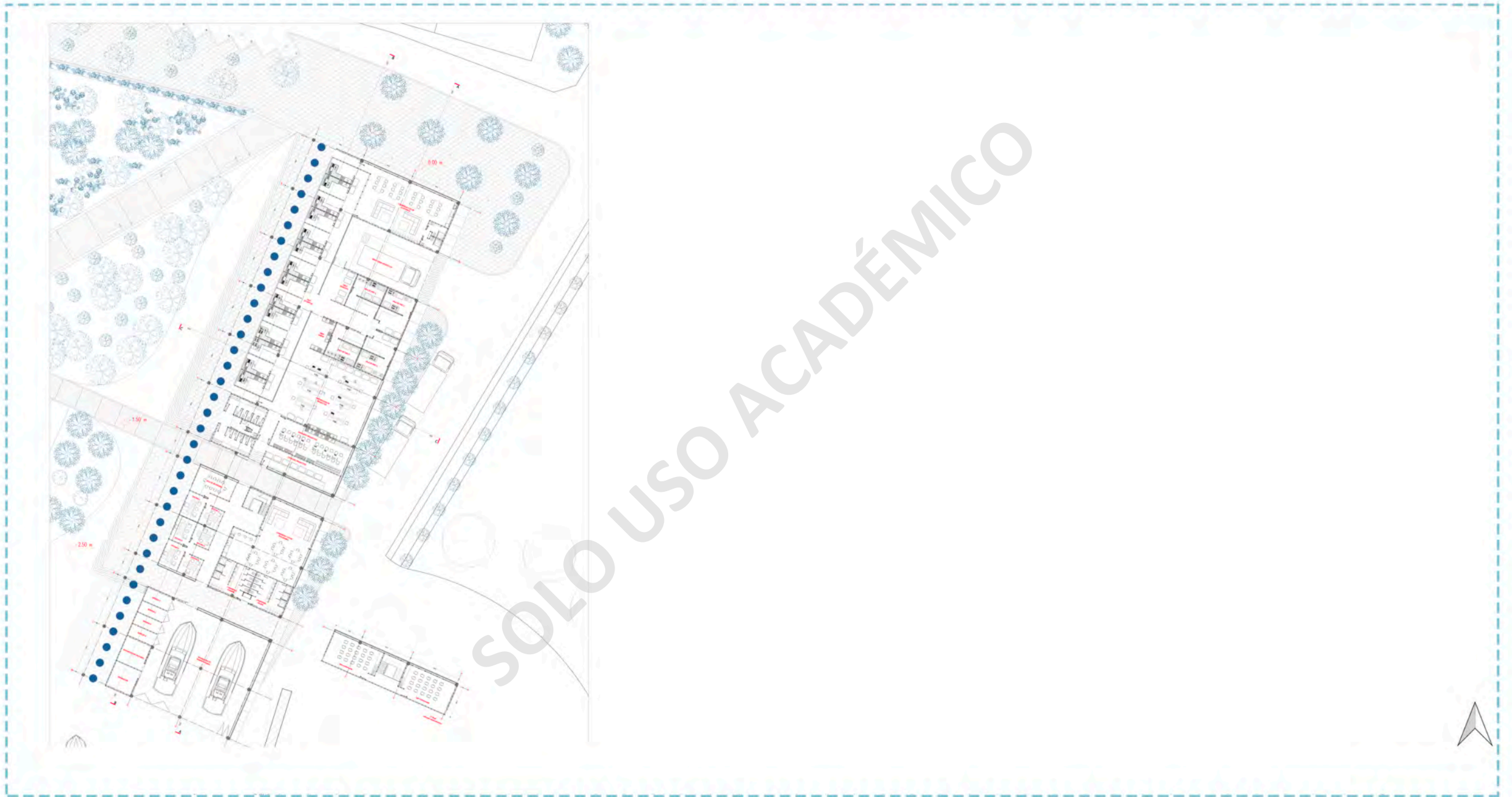

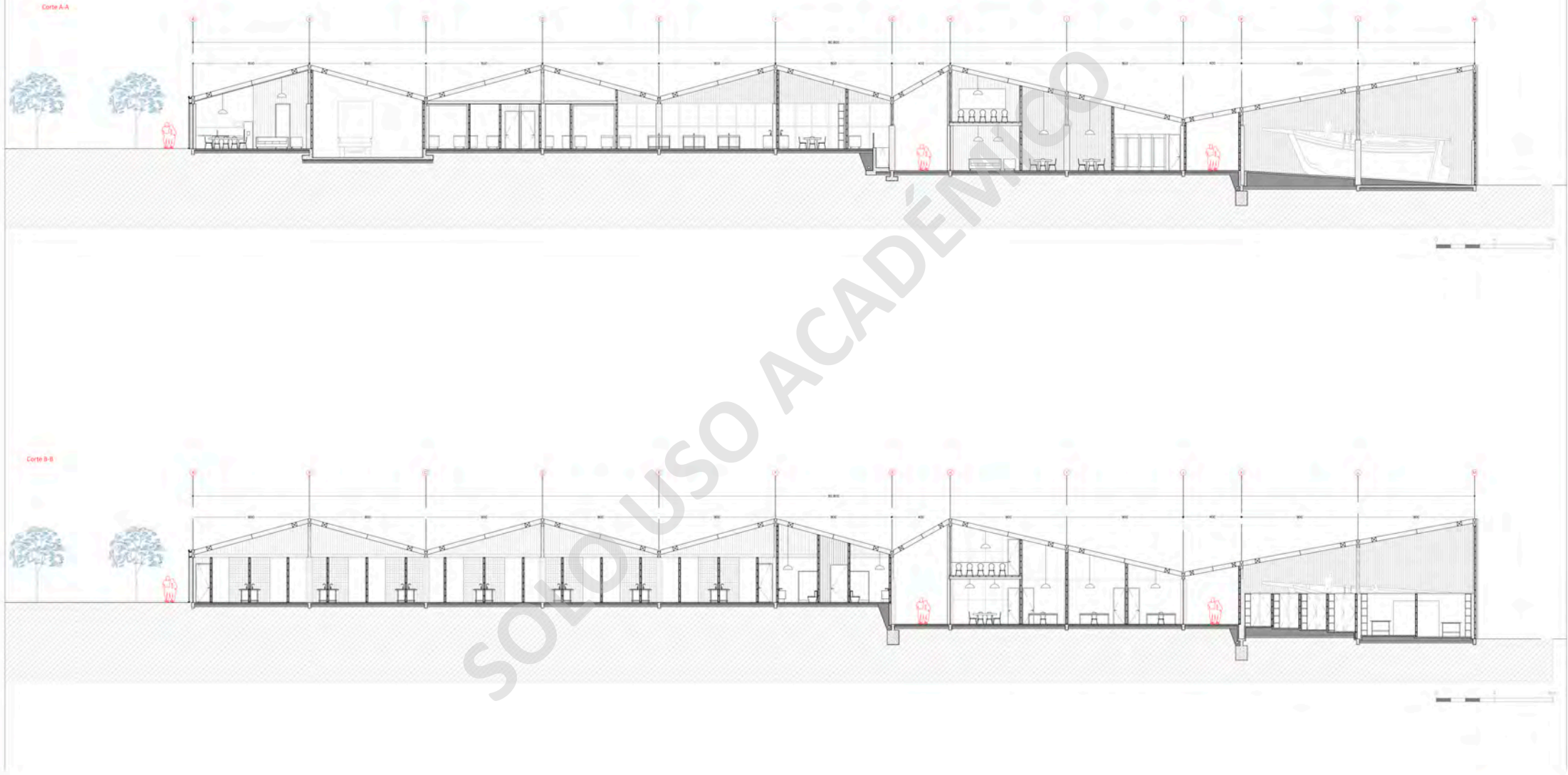

PROYECTO
Isométrica dinámica recorrido

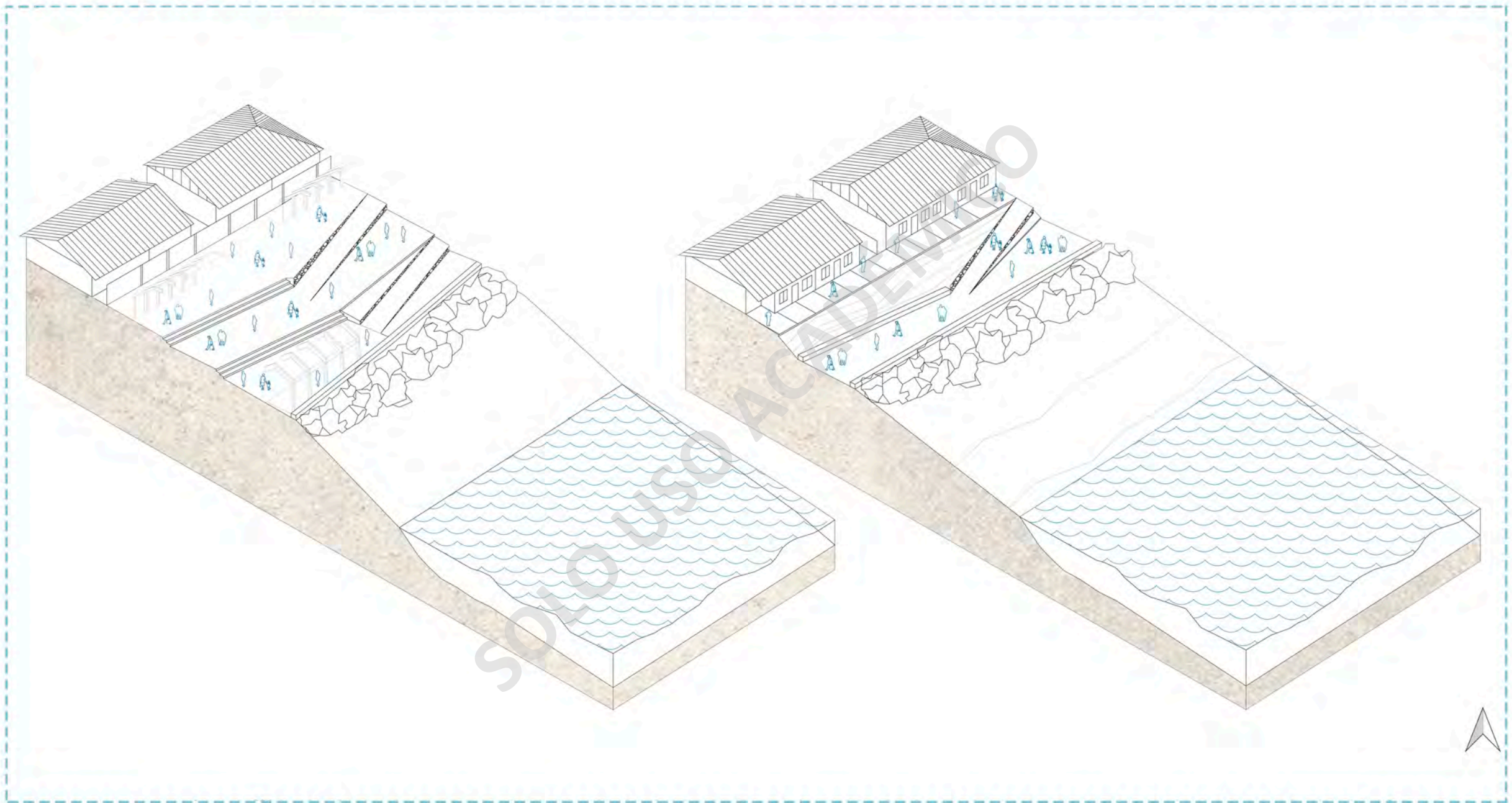

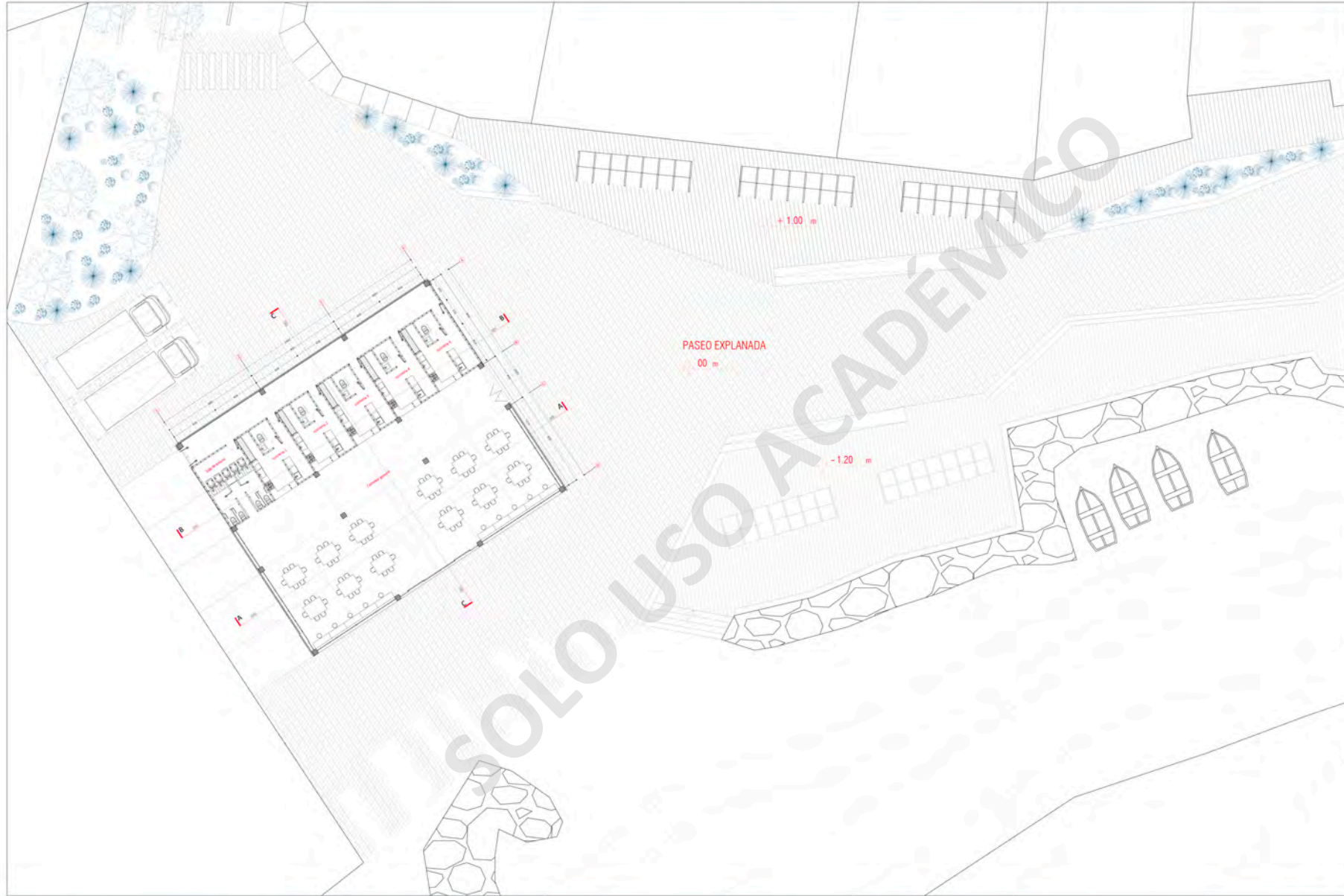





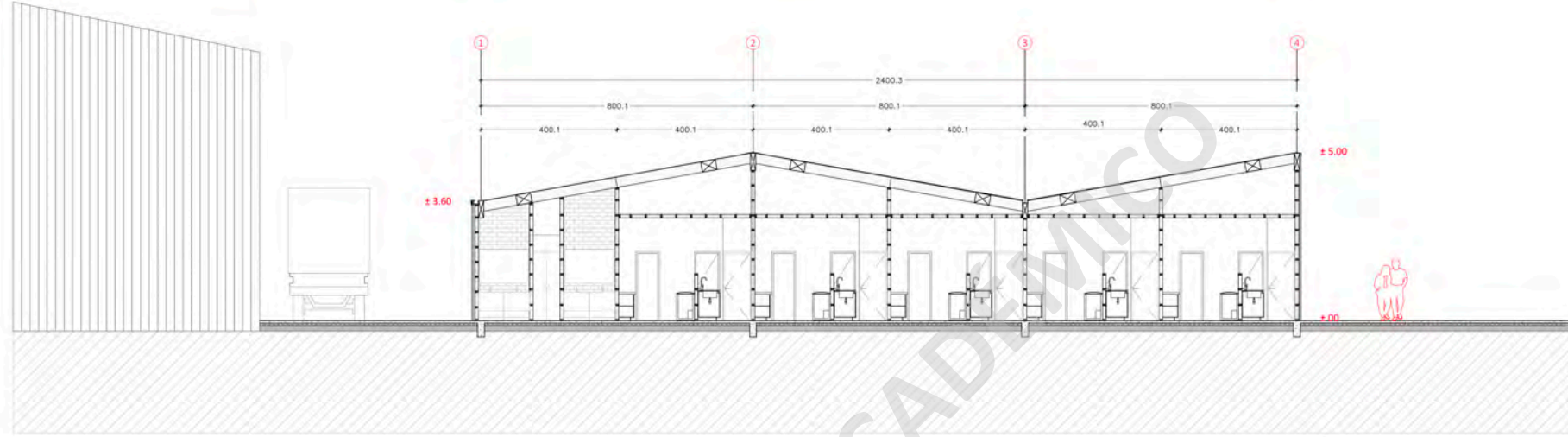

Corte B-B

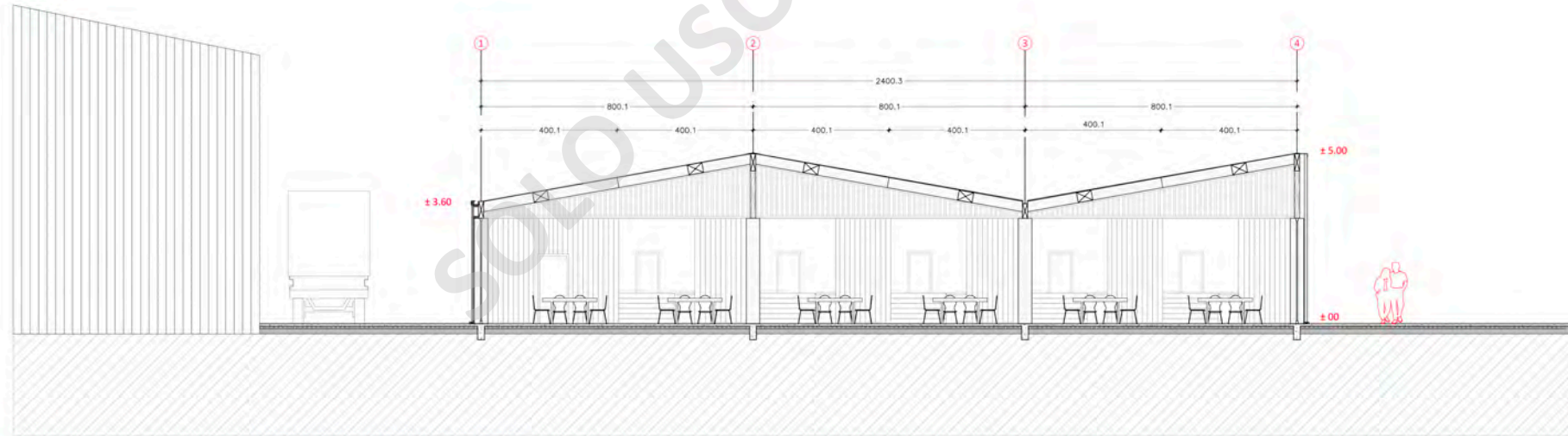

IMÁGENES DE PROYECTO

Vista Aérea



IMÁGENES DE PROYECTO

Vista Aérea_Volumen Centro pesquero + Multicancha



IMÁGENES DE PROYECTO
Fachada norte_Volumen Centro pesquero



IMÁGENES DE PROYECTO

Preparación de productos _Volumen Centro Pesquero



IMÁGENES DE PROYECTO

Puestos de venta



IMÁGENES DE PROYECTO
Fachada Sur _Volumen Centro Pesquero



IMÁGENES DE PROYECTO
Volumen Centro Pesquero



IMÁGENES DE PROYECTO

Recorrido



IMÁGENES DE PROYECTO

Recorrido



IMÁGENES DE PROYECTO

Volumen Cocineria



IMÁGENES DE PROYECTO

Conclusión





UNIVERSIDAD
MAYOR

para espíritus emprendedores

Facultad de Humanidades

**ESCUELA DE
ARQUITECTURA**

Abril 2022